

RSL15 US

List of luminaire components

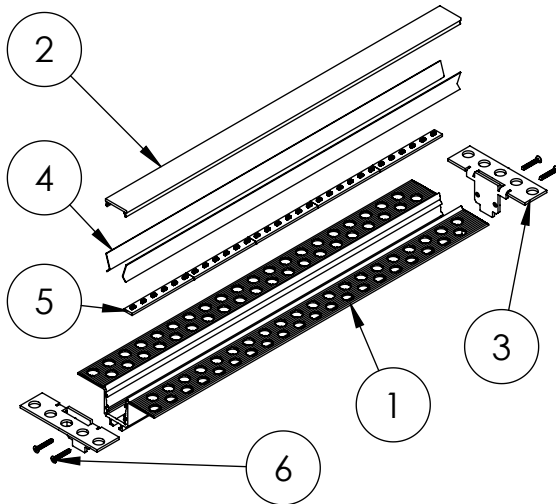

Item	Code	Comments	Quantity
1	AL-RSL15 US	2, 3 or 6.1 [m]	1
2	AB-SL15 FL	2, 3 or 6.1 [m]	1
3	EC-RSL15 US	end cap	2 per luminaire
4	AL-REF13-B60	reflector Vega 95 1,98 or 2,98 [m]	2 per profile
5	6-DURIS	PCB 24VDC LEDs Osram Duris E3	3 per 1 [m]
6	DIN 7982 ST2.2x9.5	in set	2 per end cap

1

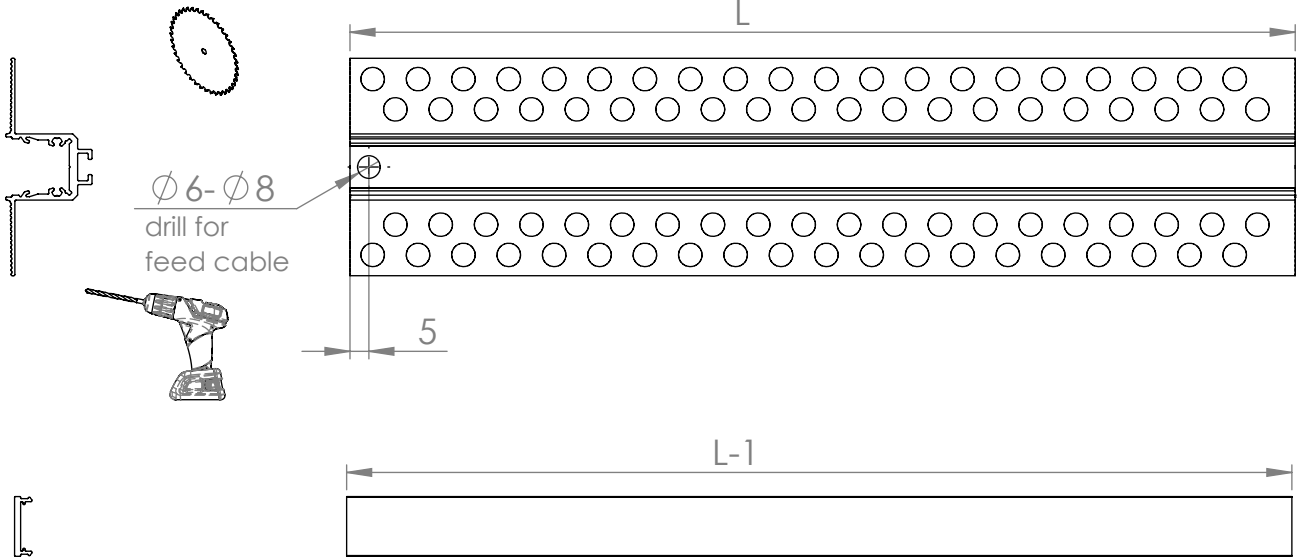

2



Slide the reflectors into the slots
Remove the protective film using gloves

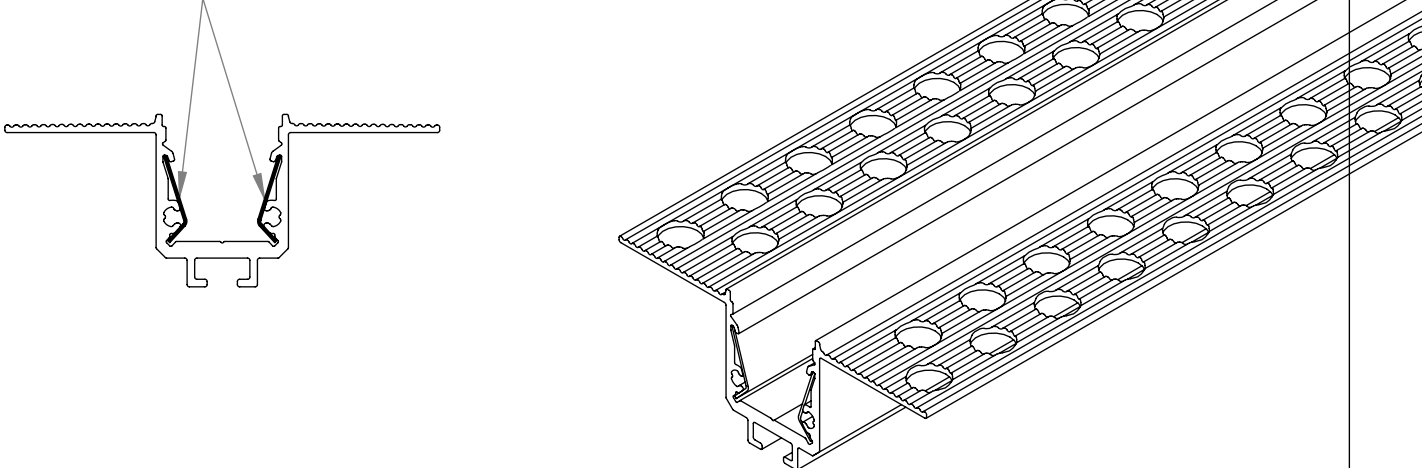

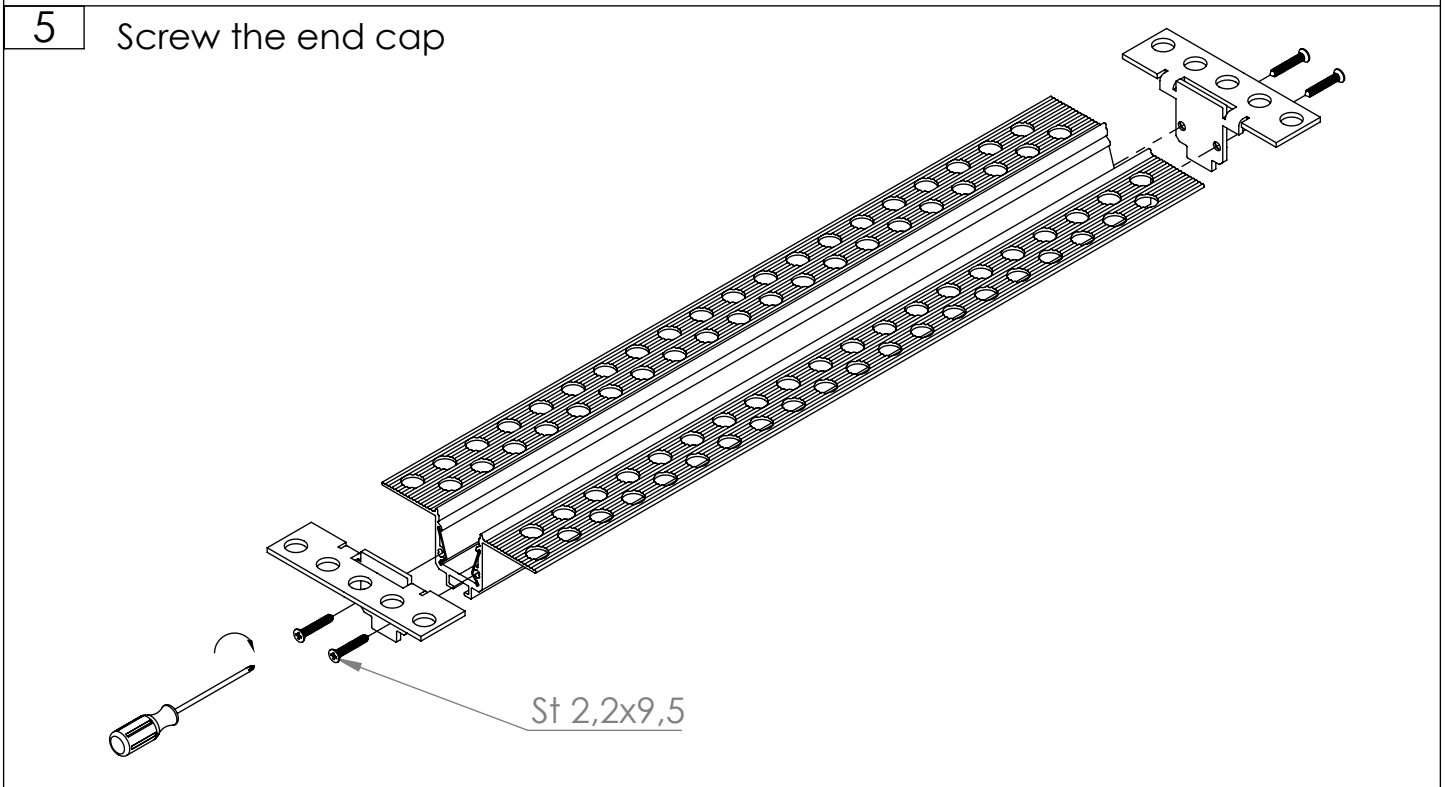
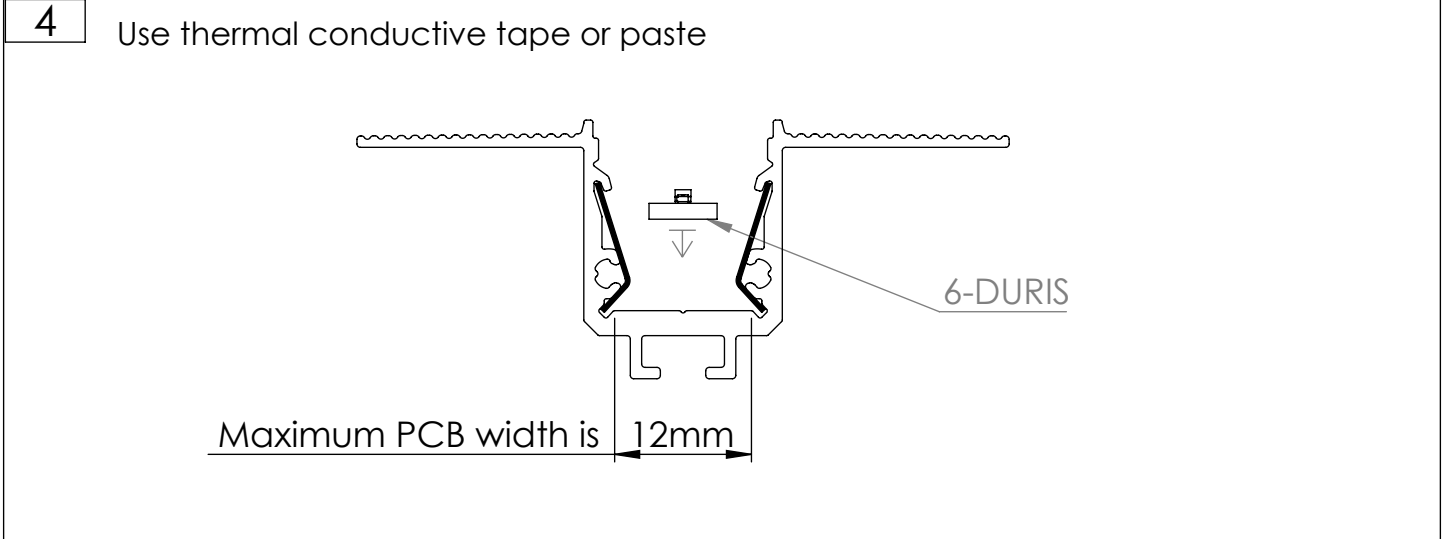
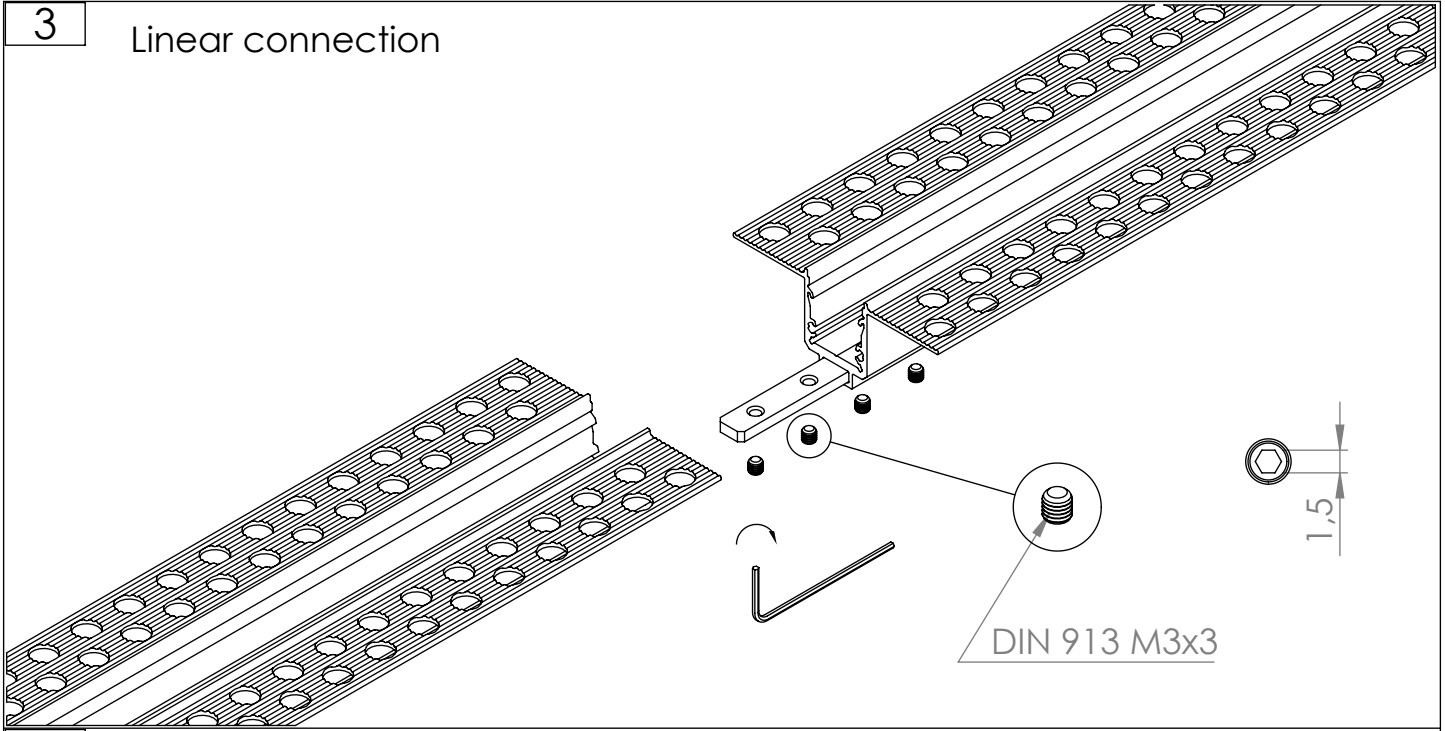

6 Cut out

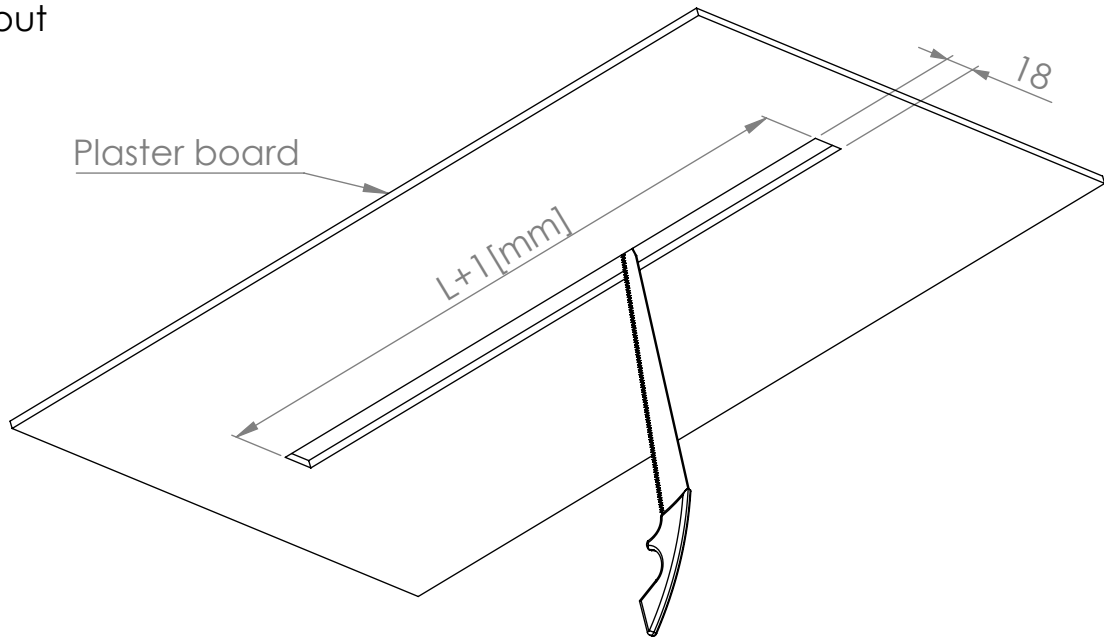

7 Connect power cable

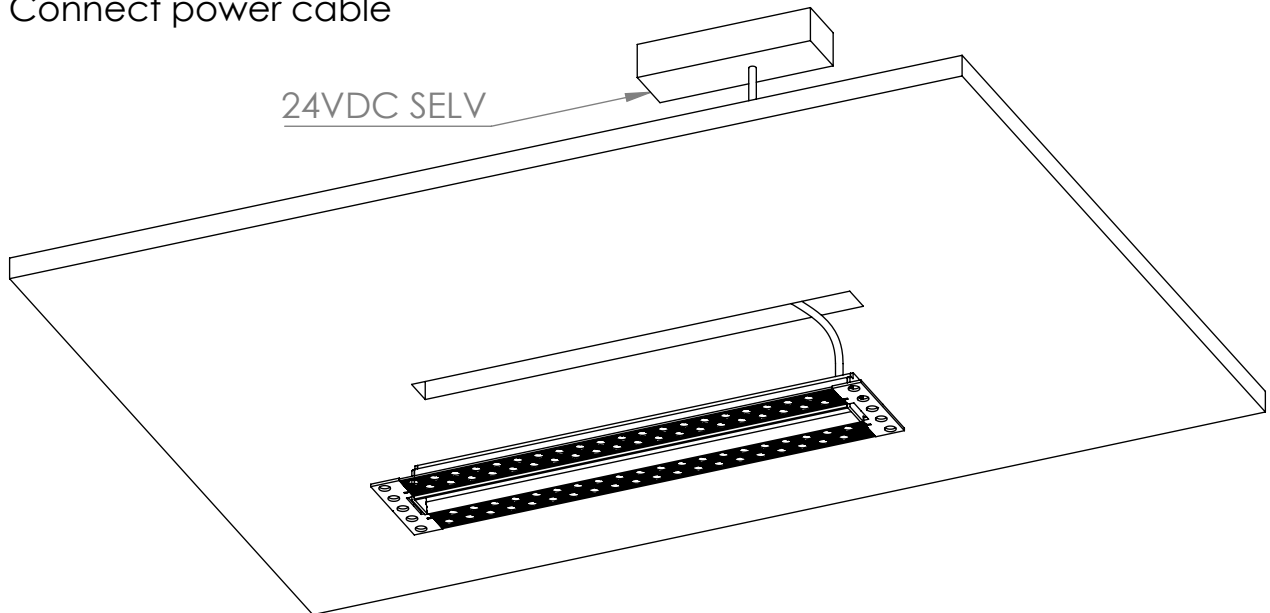

8 Screw the profile with plaster board using dedicated openings in the profile and end cap

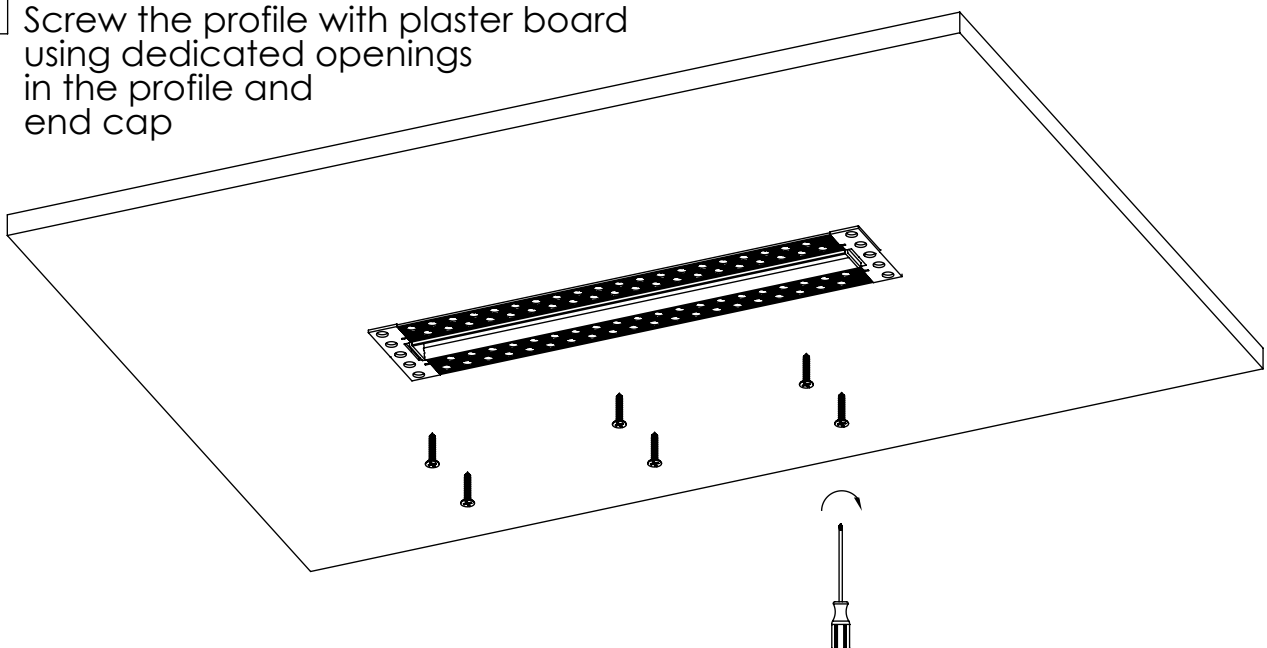

9 Click in the diffuser

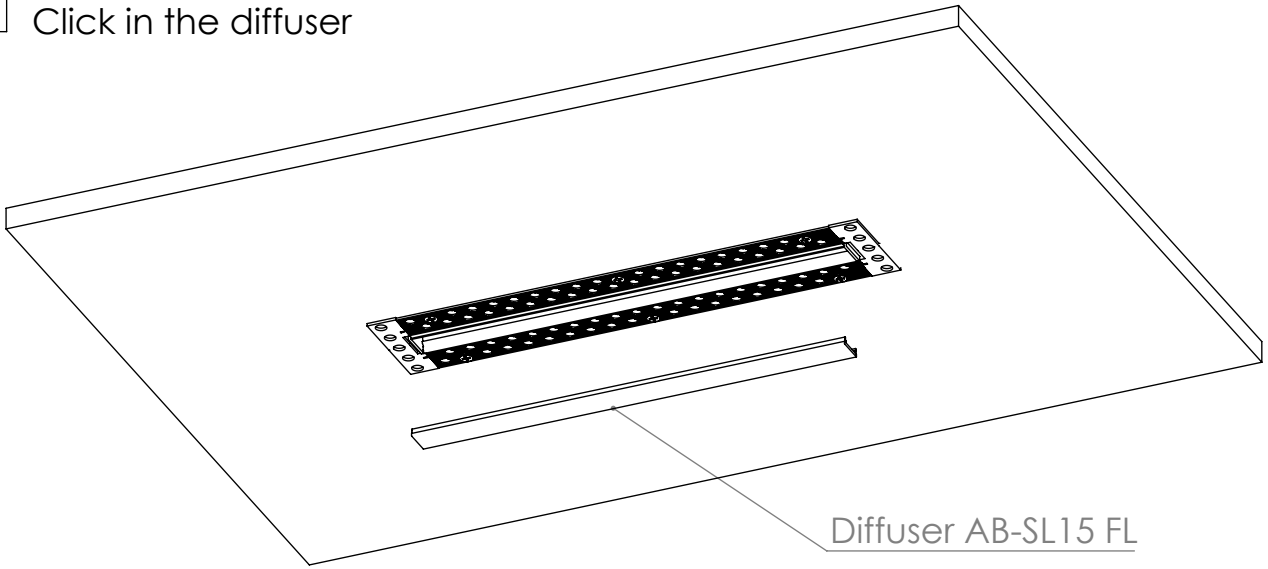

10 Cover the LED, reflectors and diffuser with protective tape before plastering

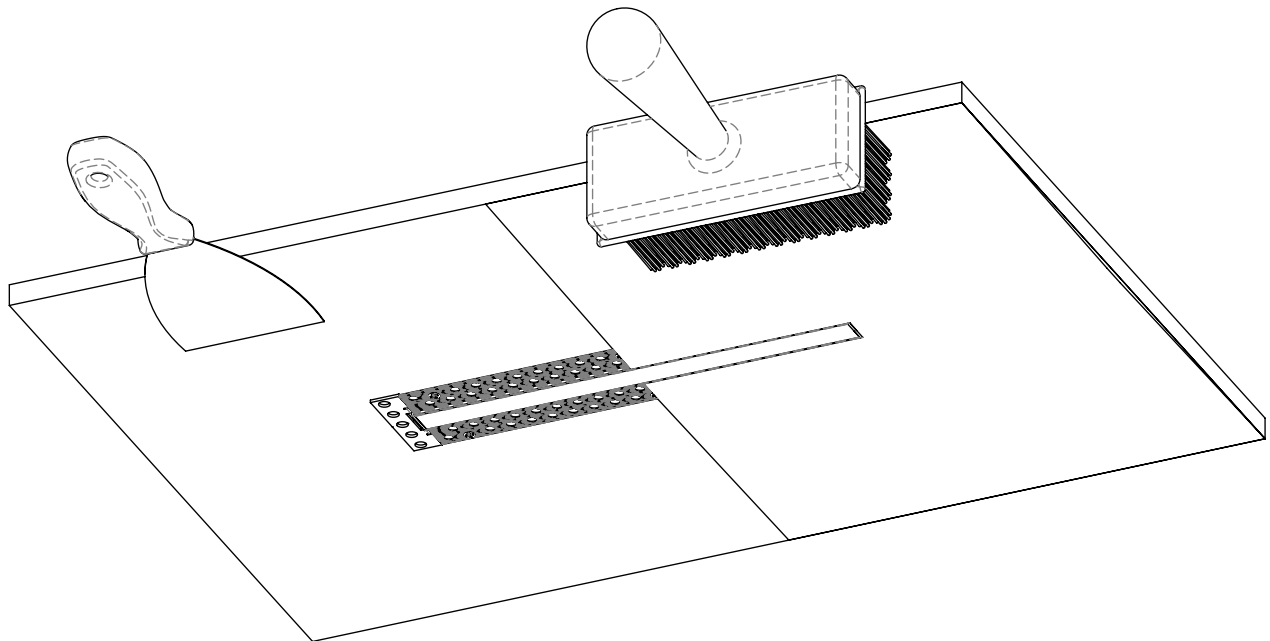

11 Remove the protective tape.
Clean the surface with alcohol to remove any dust or debris

